

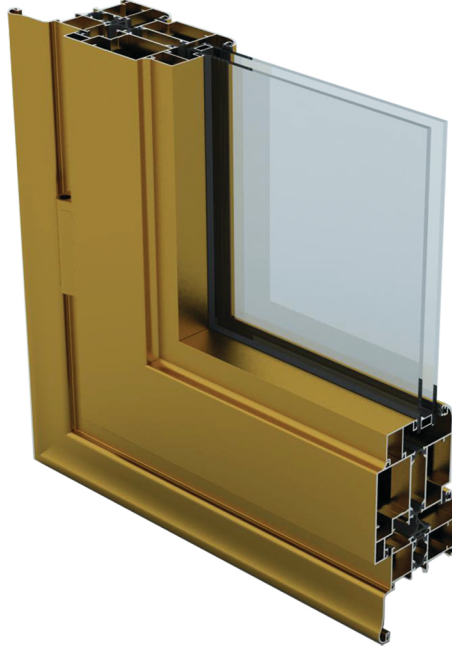

## SİSTEMLER KATOLOĞU



İZO WD 62 SERİSİ



Kaliteyi takip etmiyor kaliteye yön veriyoruz.

Kalite bizim için vazgeçilmezdir.



Türk alüminyum sanayinin en güçlü firmalarından biri olan AKPA Alüminyum, Euro normlarına uygun olarak ürettiği her üründe teklif aşamasından ürünün teslimatına kadar Kalite Yönetim Sistemi uyguluyor.

AKPA Alüminyum TSE 755-1, TSE 5247 en 12020-01, TSE 4922, ISO 9001:2000 CE belgelerinin yanında QUALICOAT ve IFT ROSENHEIM kalite sertifikalarına sahip olarak tüm ürünlerinde yüksek kalite standartlarını belgelendirmiştir.

Tüm üretim süreçlerinde yüksek kalitenin önemini bilen içinde uzman 550 eğitilmiş ve deneyimli personeli ile 80000 metrekarelik tesislerinde;

Yıllık 1400 adet kalıp üretimi

Aylık 4 pres hattı ile toplamda 2000 ton profil üretimi

Aylık 1000 ton eloksal üretimi

Aylık 1200 ton Elektrostatik üretimi

Aylık 100 ton ahşap kaplama film üretimi kapasitesine sahiptir.





AKPA Alüminyum yatırımlarına hız kesmeden devam ediyor.



1986 yılından beri Türk alüminyum sektörünün güçlü oyuncularından biri olarak varlığını devam ettiren AKPA Alüminyum, dökümhane, kalıp üretim hattı, ekstrüzyon tesisi, boya hattı, eloksal hattı, mekanik arıtma ve yükleme departmanları ile entegre bir tesistir.

Kurulduğu günden bu yana sürekli büyüme misyonuyla hareket eden AKPA Alüminyum, sektörün ihtiyaçları doğrultusunda yeni yatırımlar yaparak sektördeki güçlü konumunu sürdürüyor.

Tüm üretim süreçlerinde yüksek müşteri memnuniyetini esas alan AKPA Alüminyum, modern üretim tesislerinde, inovatif ürün gamını yurt içi ve yurtdışından tüm müşterilerine güvenle sunuyor.

Yurtiçi pazarlarındaki güçlü konumunu yurtdışı pazarlarda da devam ettiren AKPA Alüminyum, kaliteli ürünlerini tüm dünyaya güvenle ulaştırıyor.



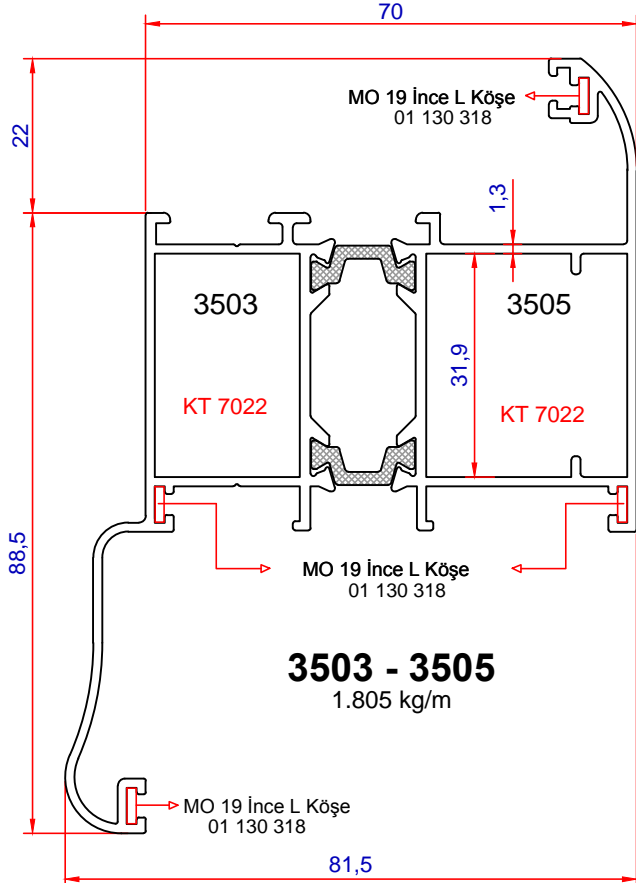
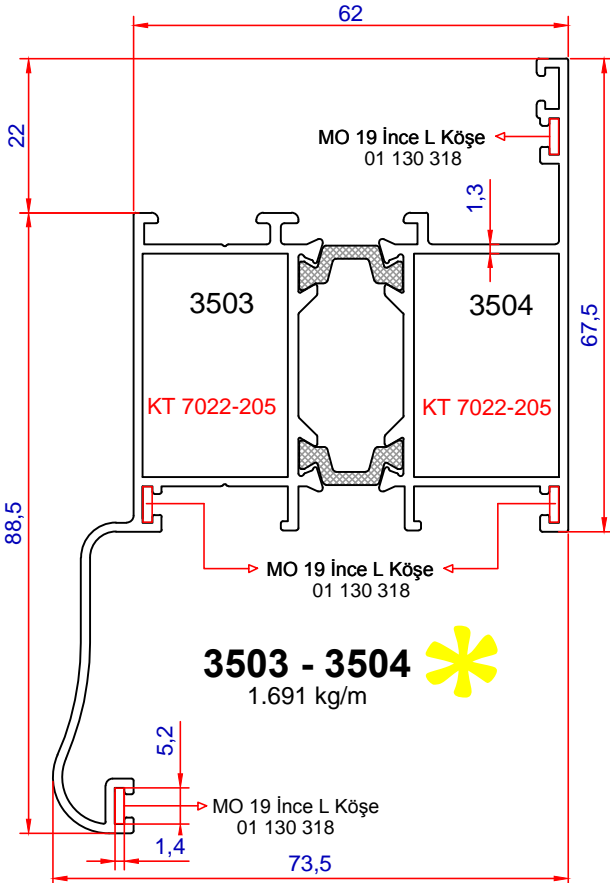
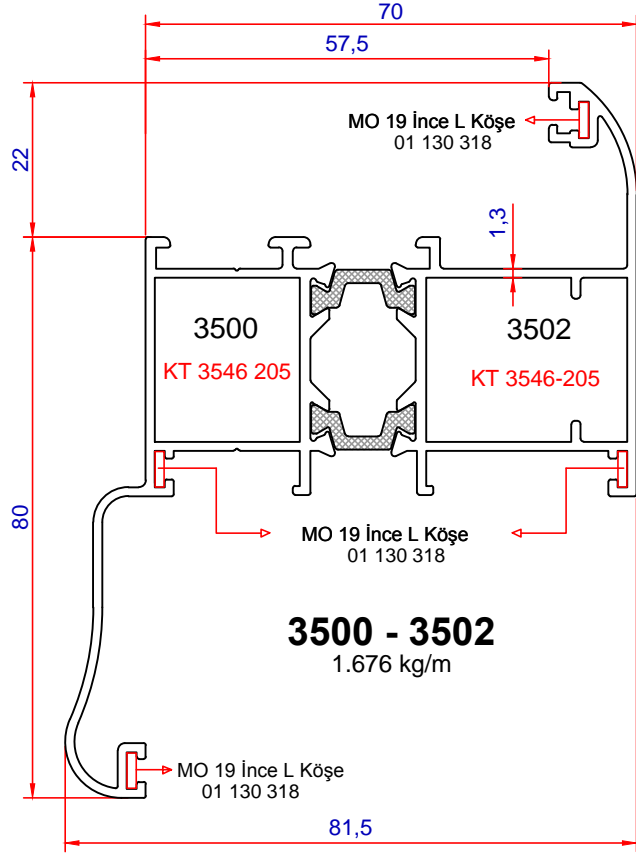
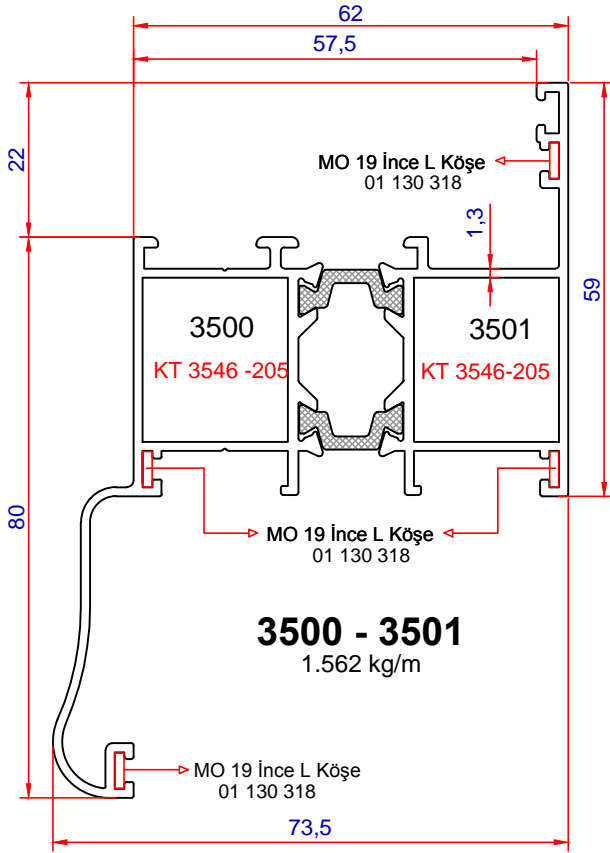



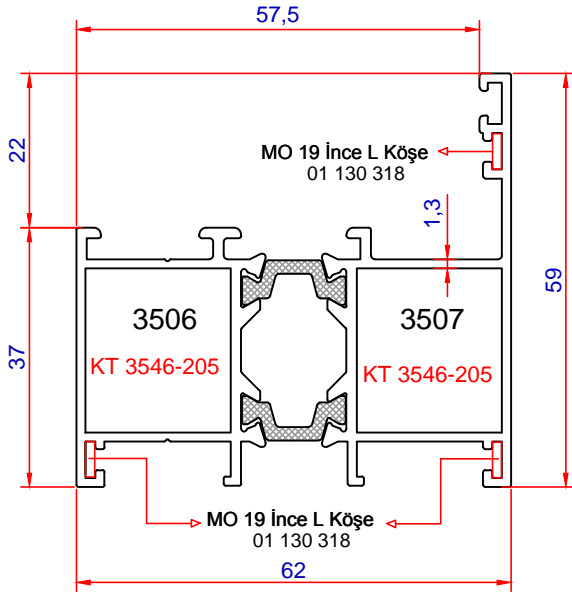

**3506 - 3507**  
1.325 kg/m

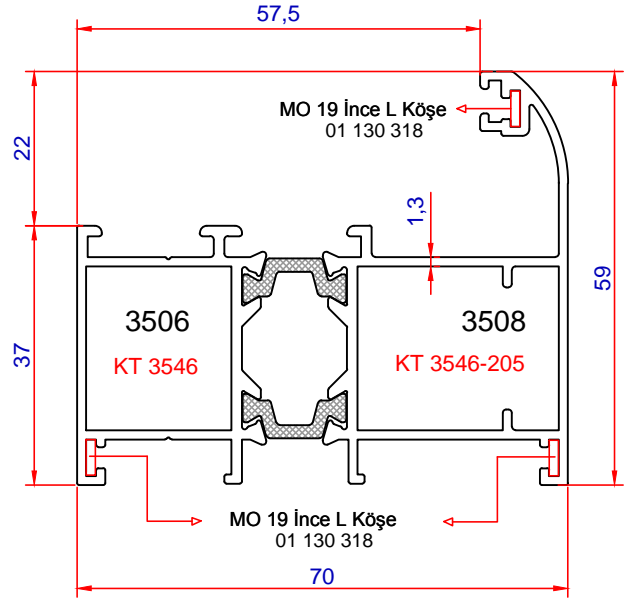

**3506 - 3508**  
1.439 kg/m

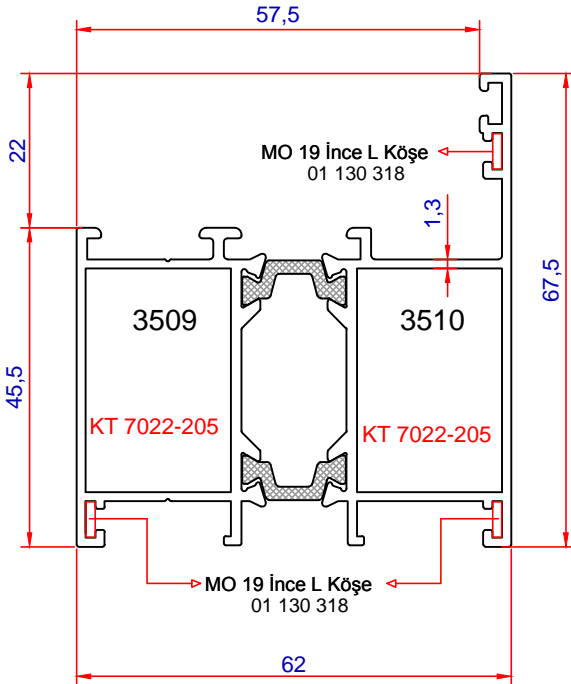

**3509 - 3510**  
1.454 kg/m

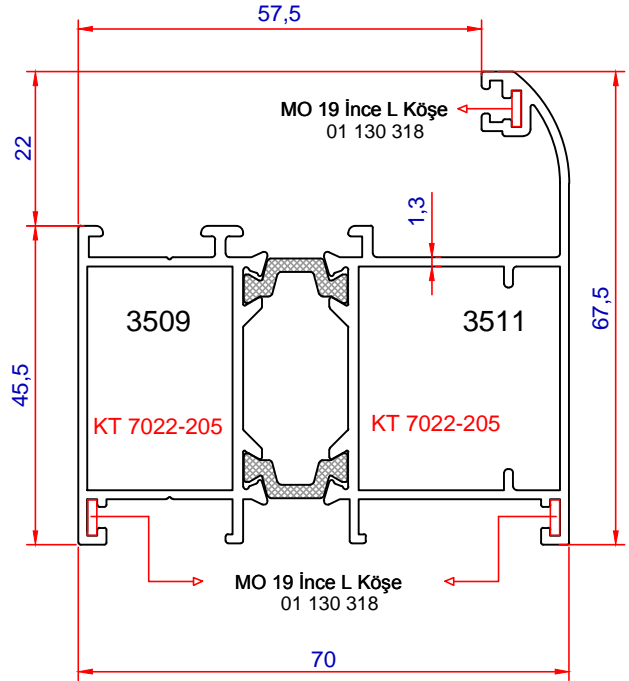

**3509 - 3511**  
1.568 kg/m

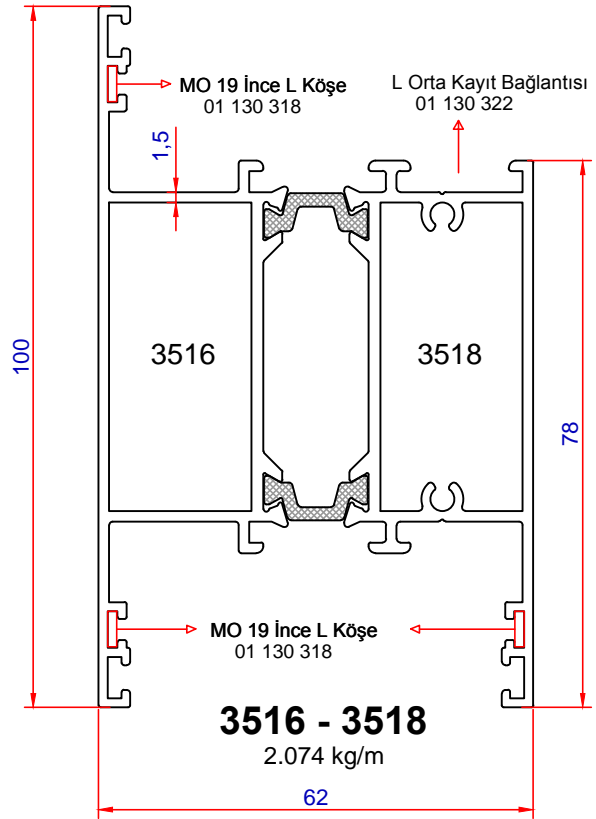
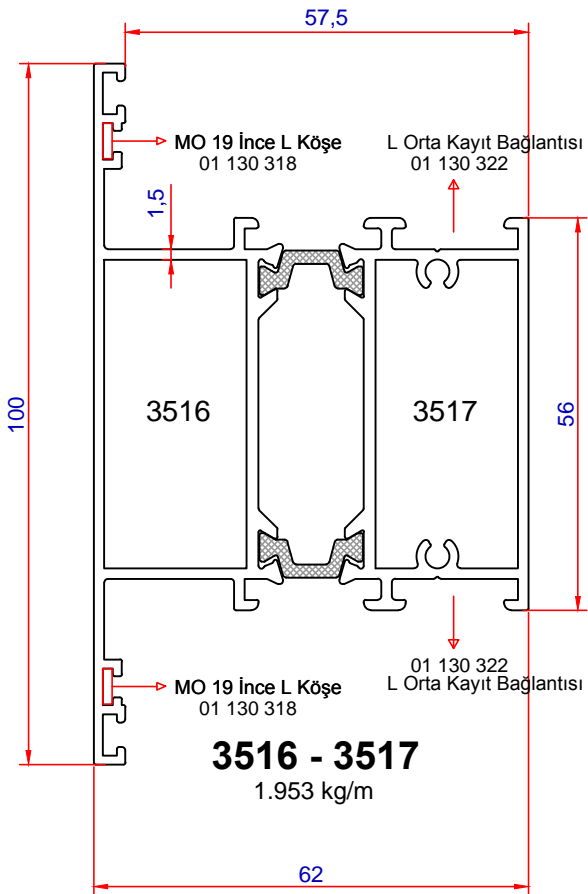
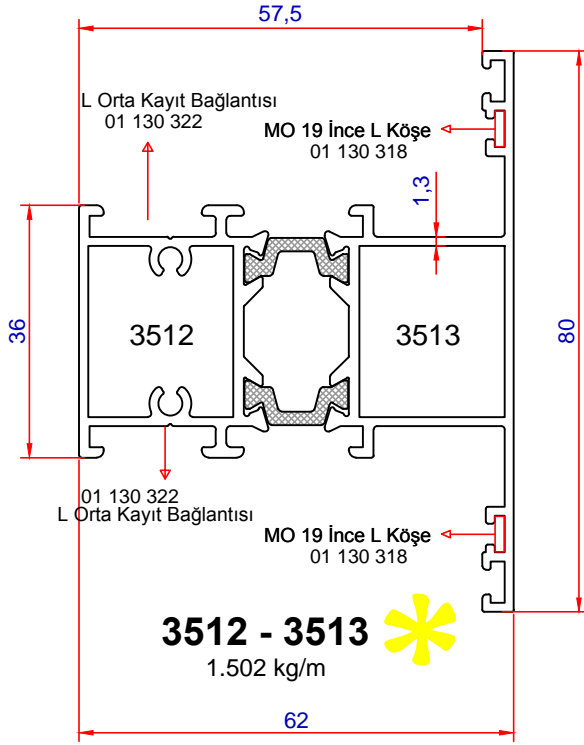

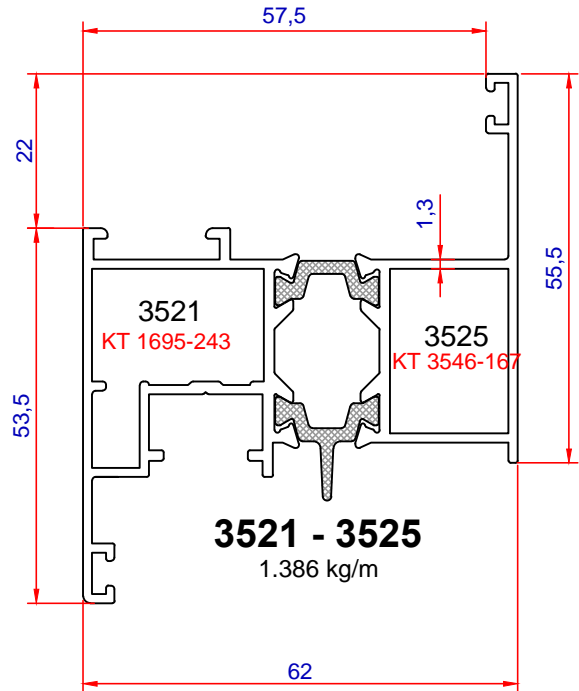
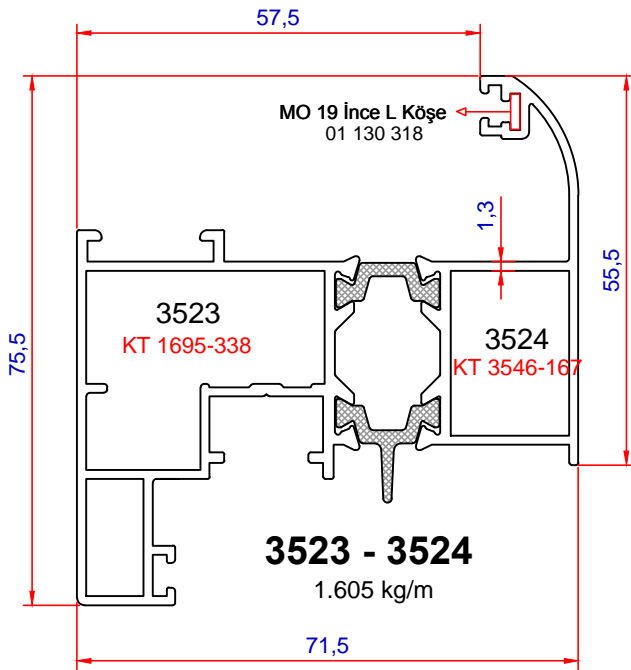
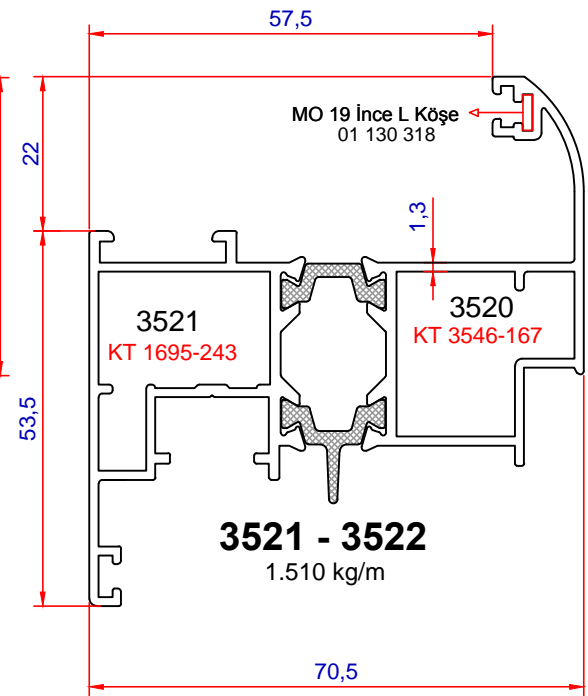
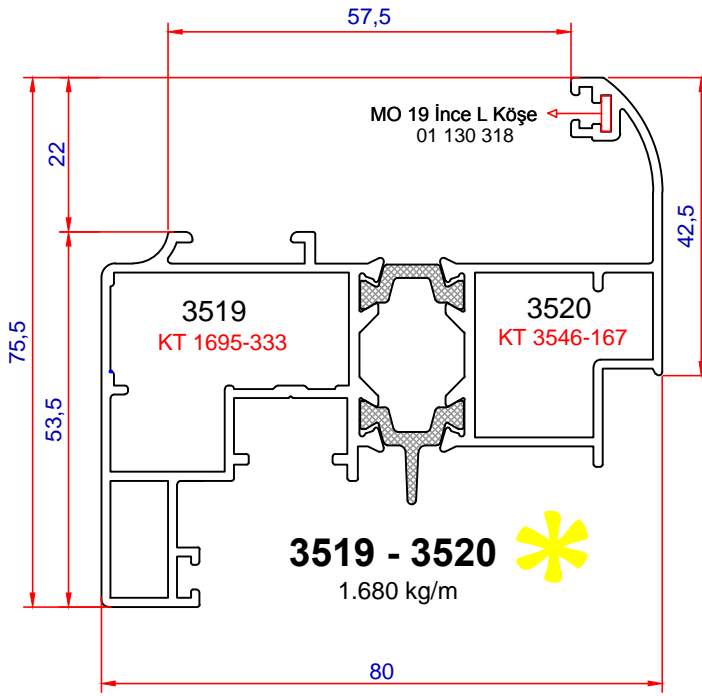

NOT:PVC DOĞRAMA AKSESUARI KULLANILIR.

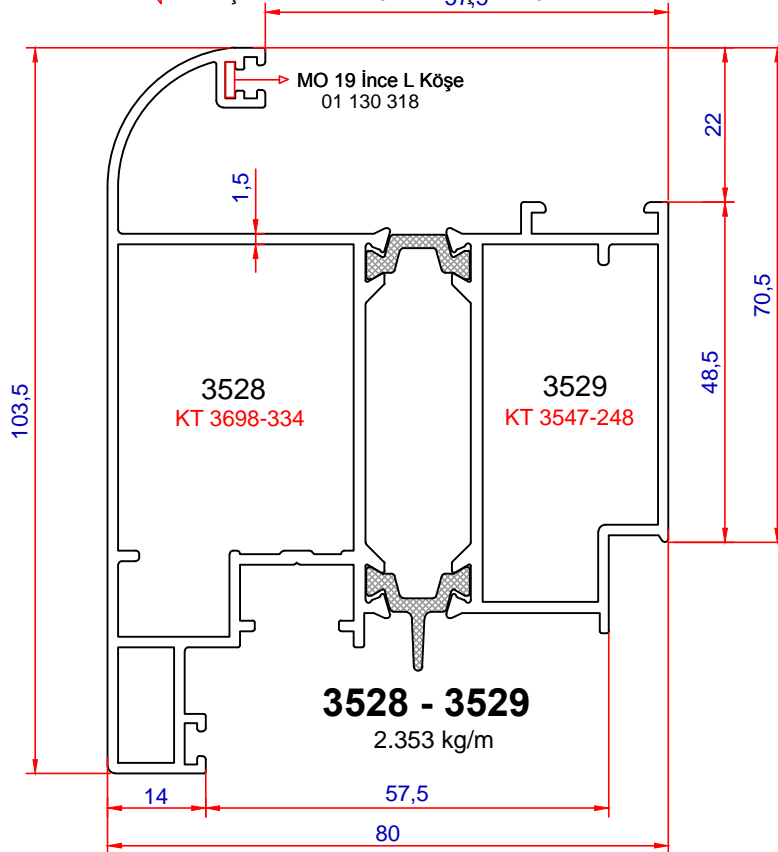
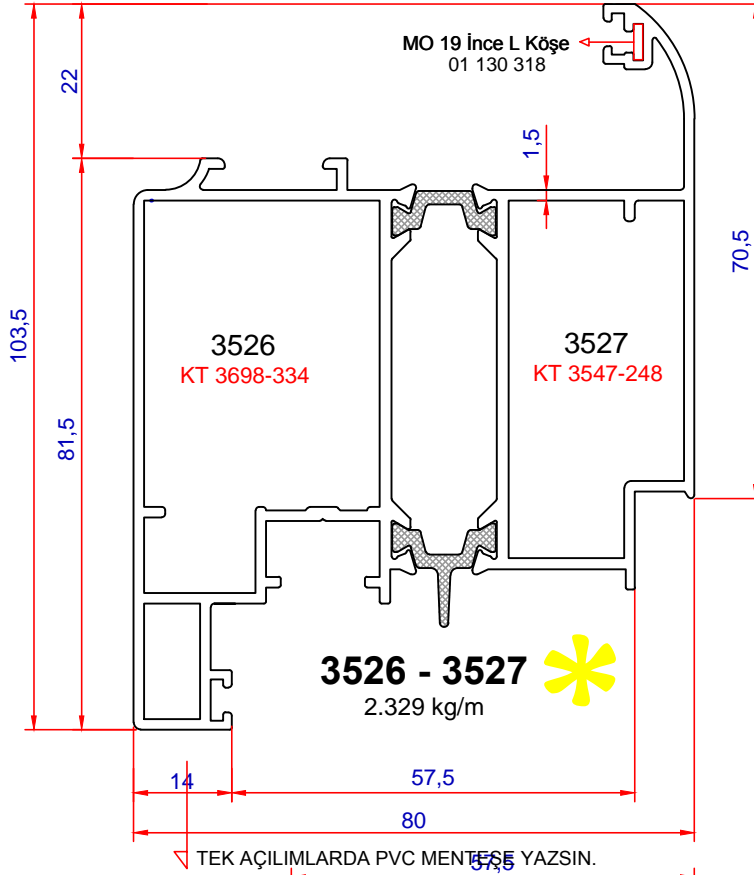

NOT: PVC DOĞRAMA AKSESUARİ KULLANILIR.

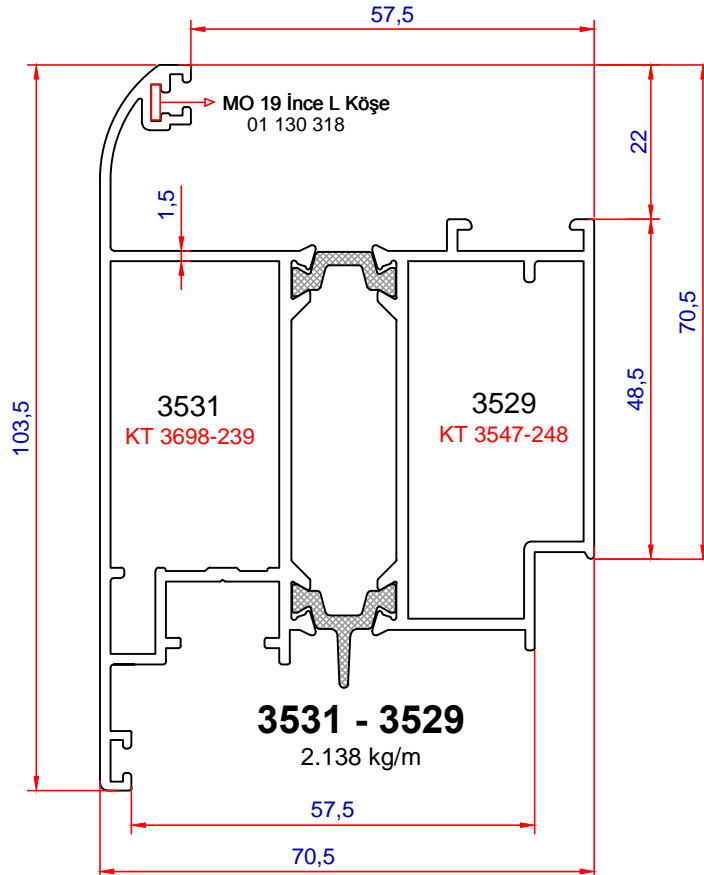
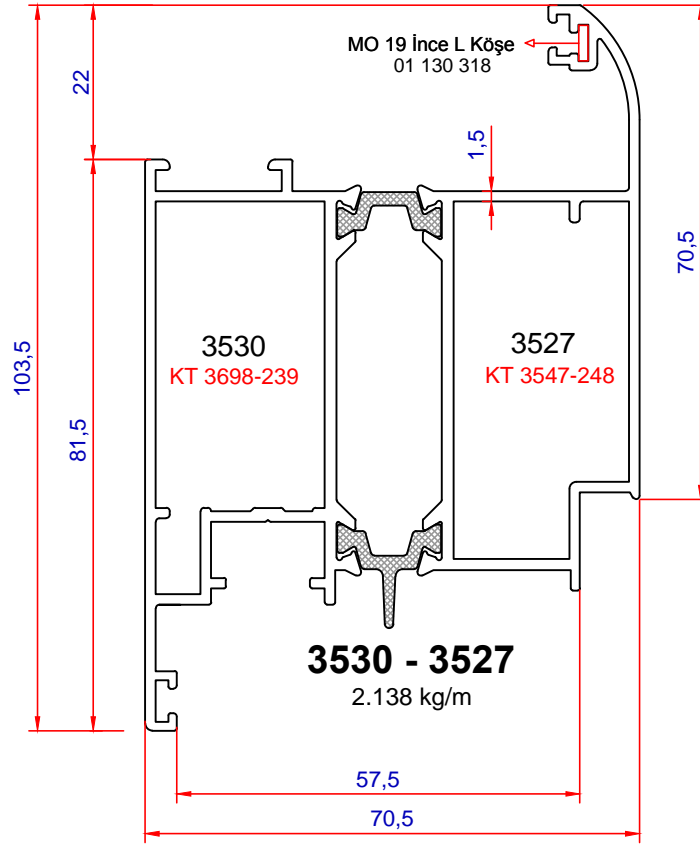



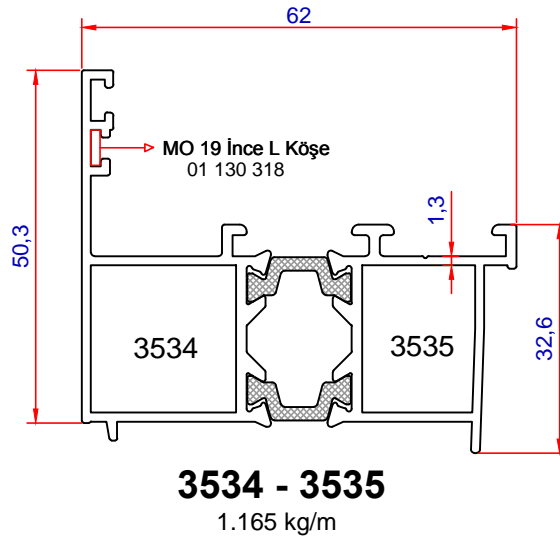
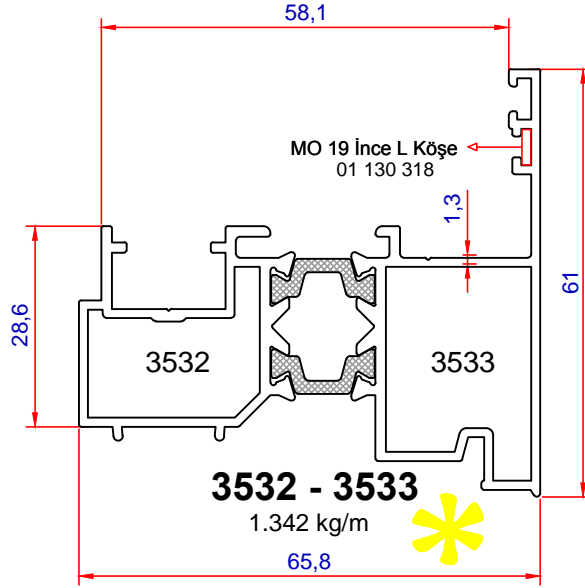

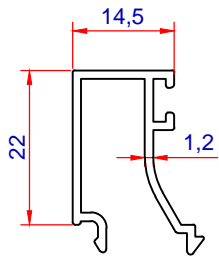

**1698**  
0.252 kg/m

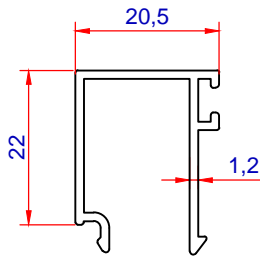

**1699**  
0.262 kg/m

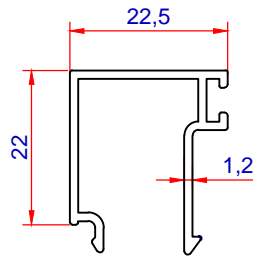

**1745**  
0.271 kg/m

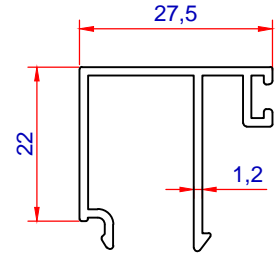

**2236**  
0.308 kg/m

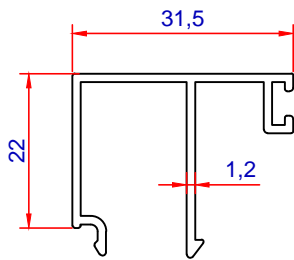

**3536**  
0.321 kg/m

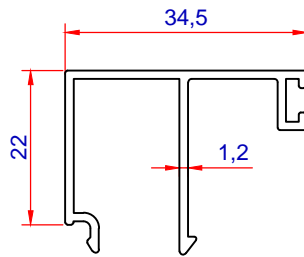

**1747**  
0.331 kg/m

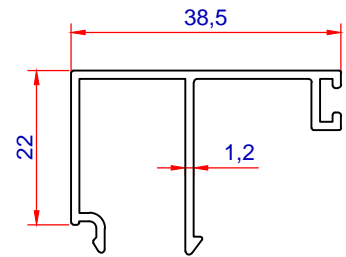

**1749**  
0.344 kg/m

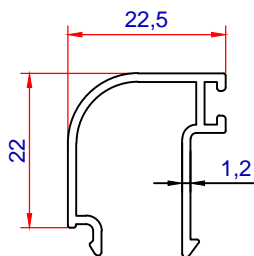

**1746**  
0.258 kg/m

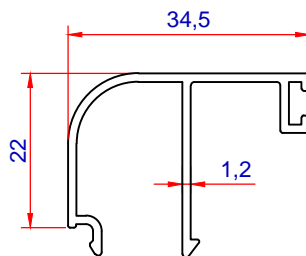

**1748**  
0.317 kg/m

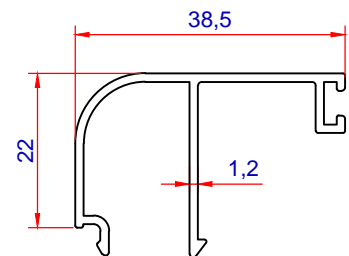

**1750**  
0.330 kg/m

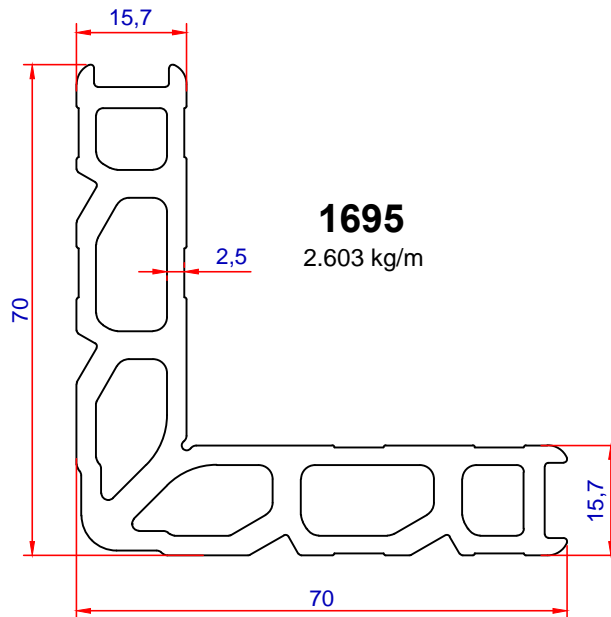
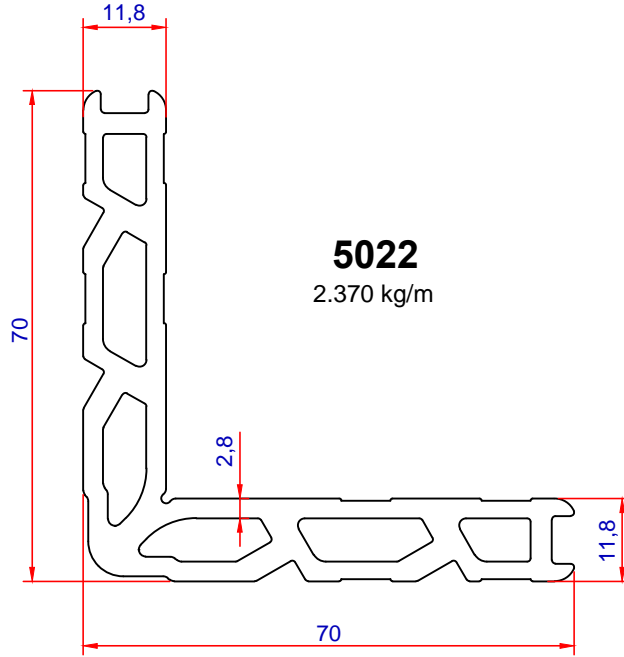

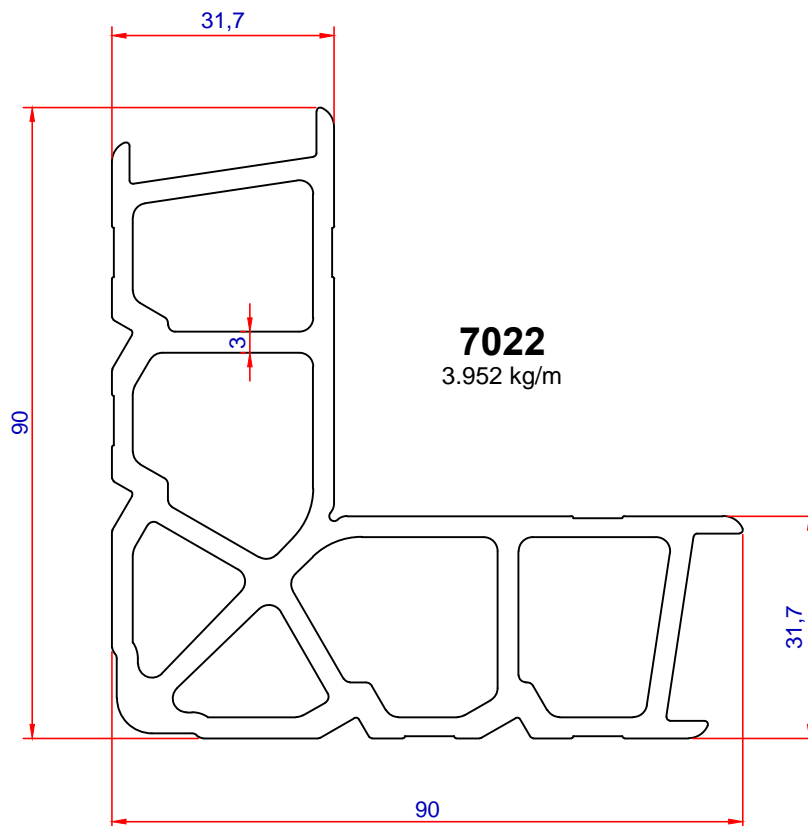
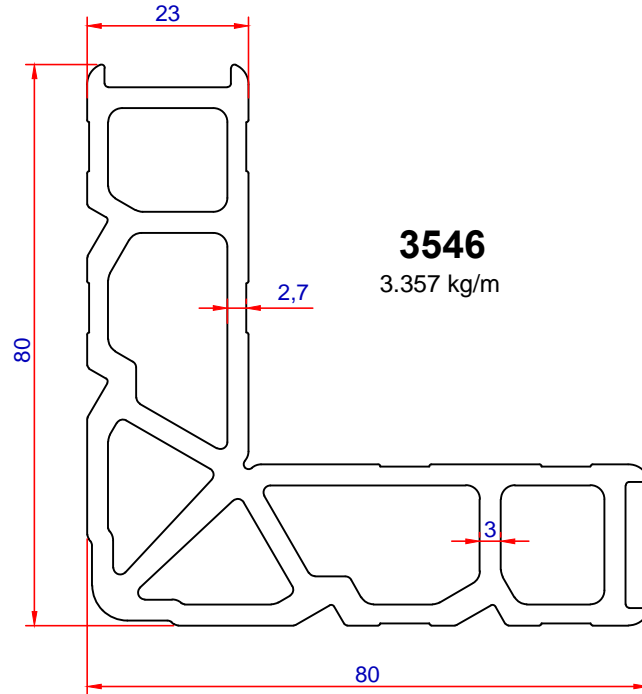

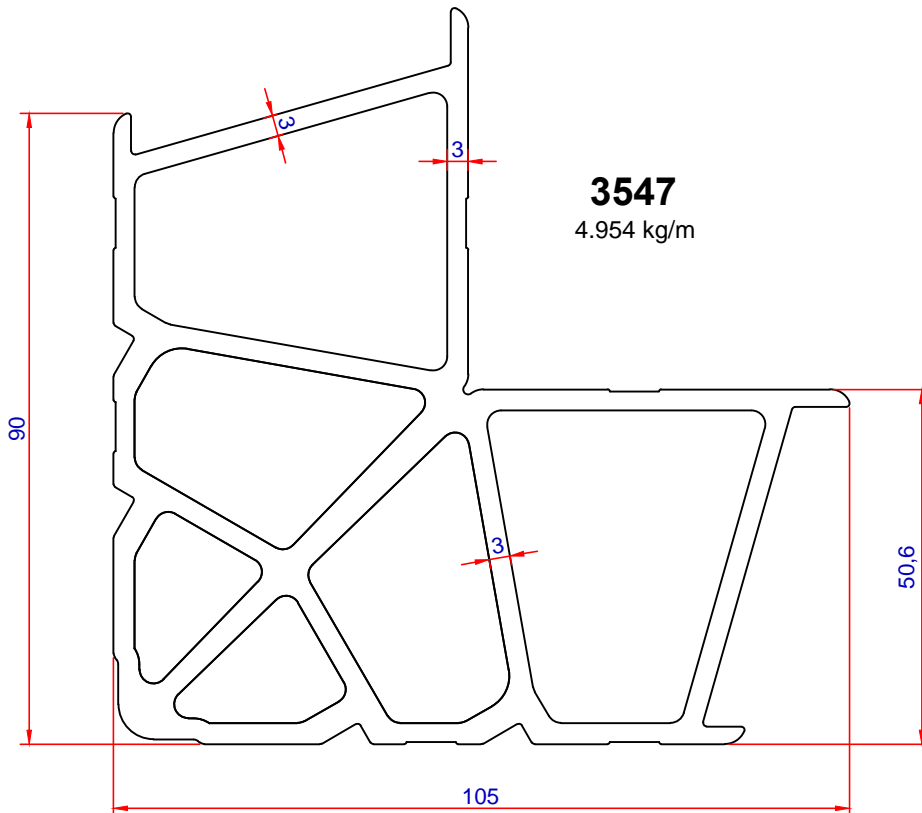
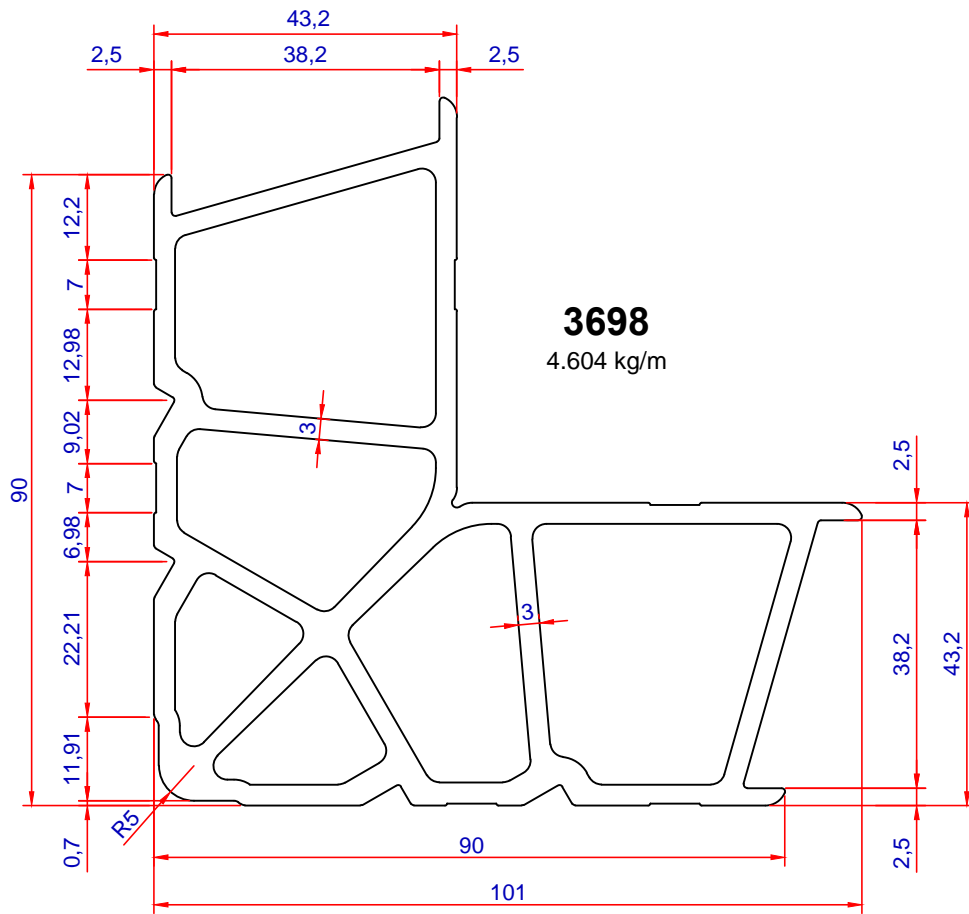



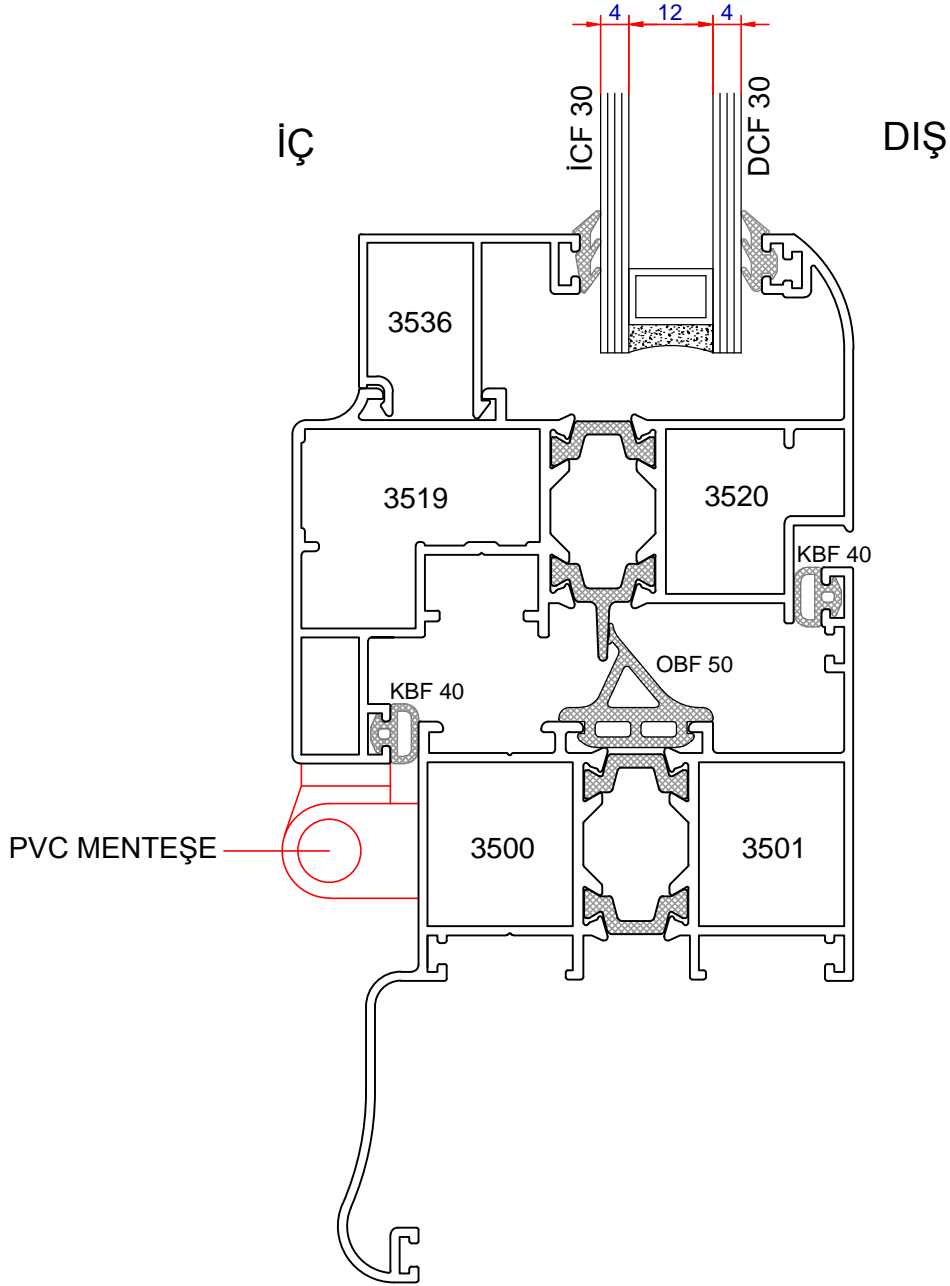

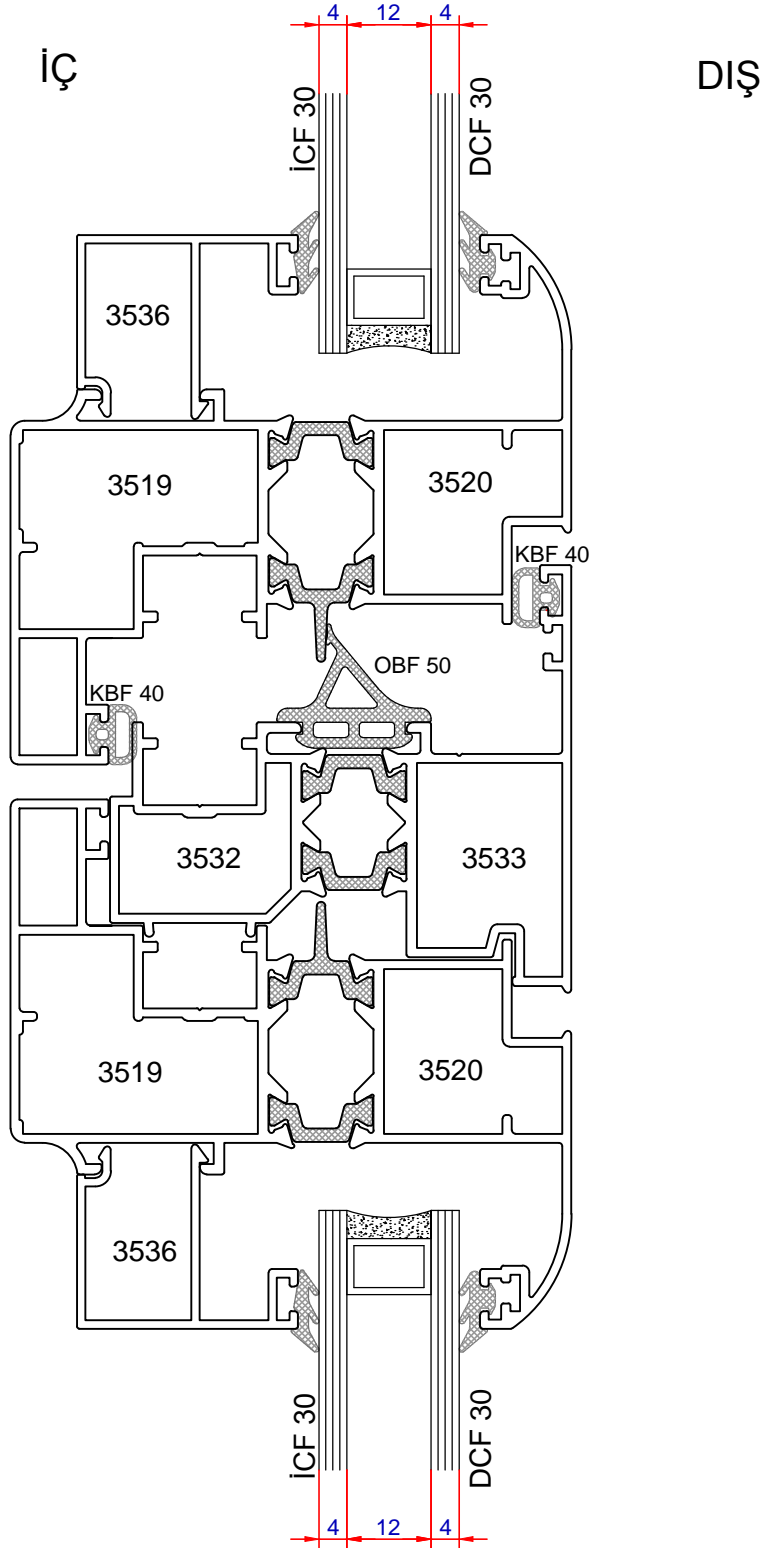

İÇ

DIŞ

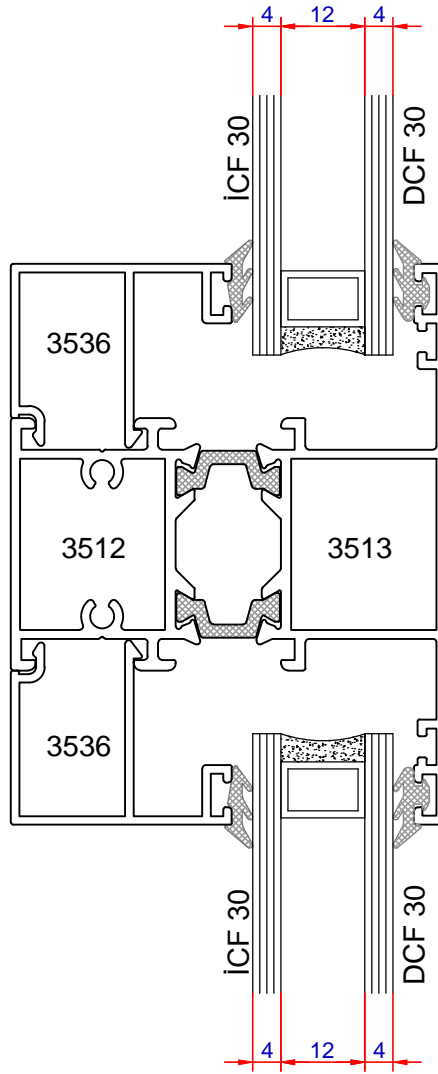

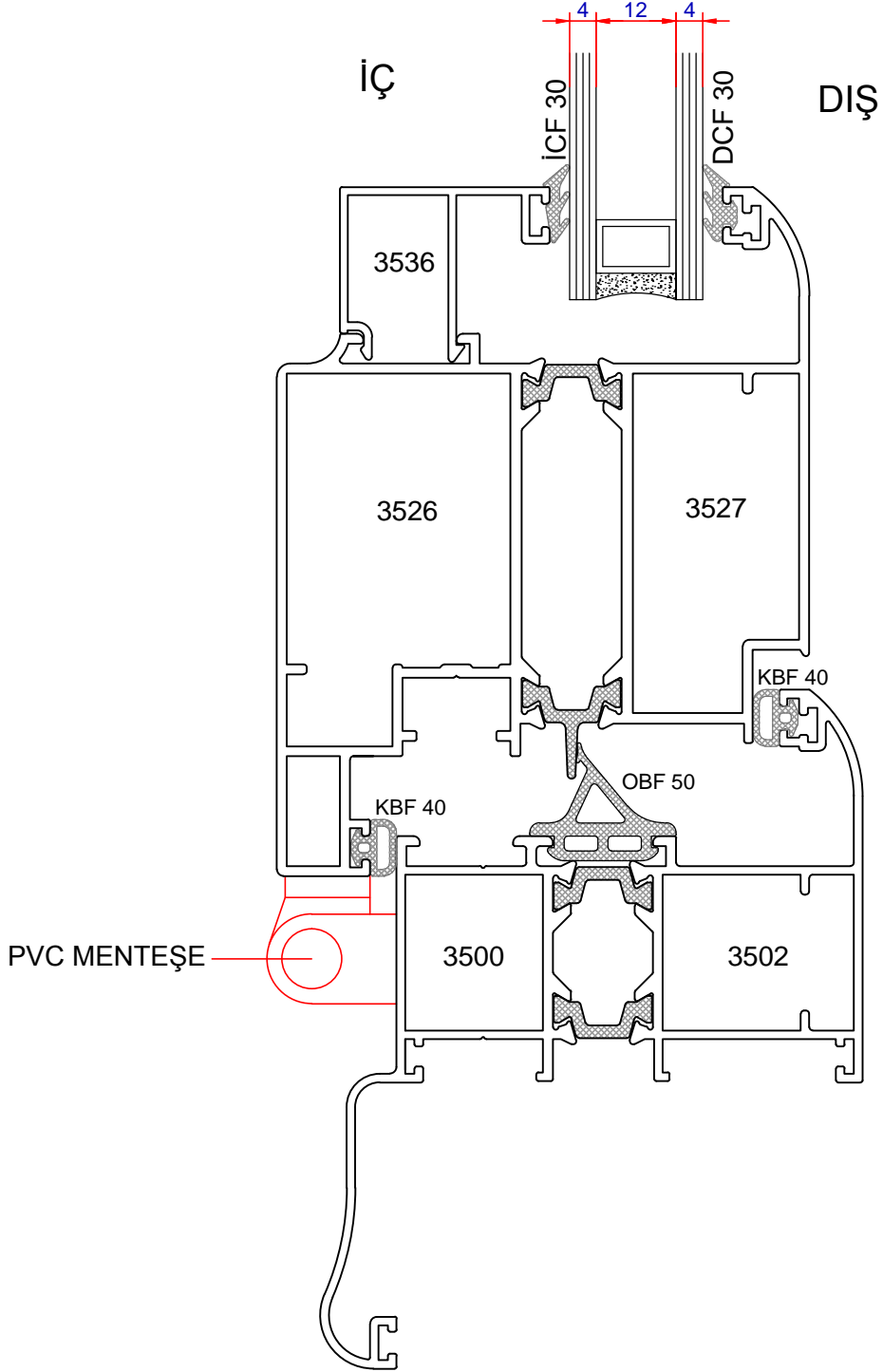





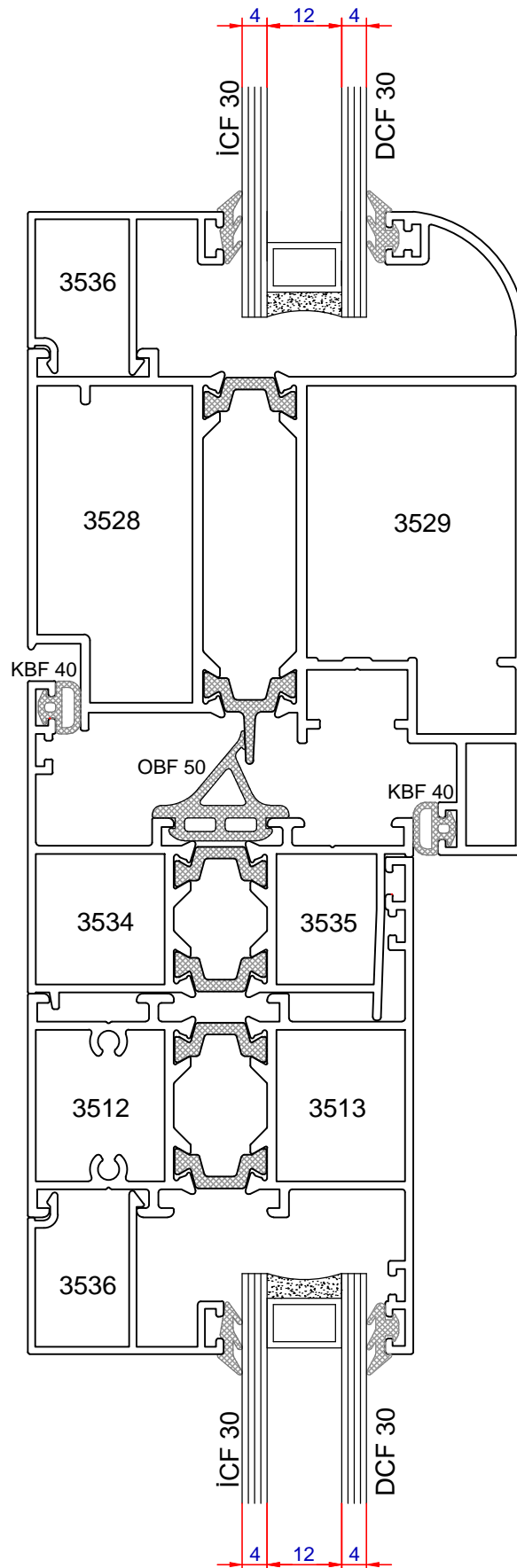

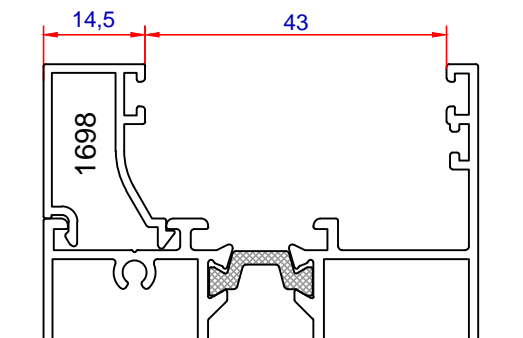
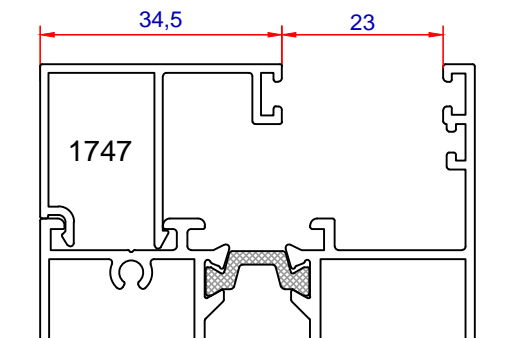
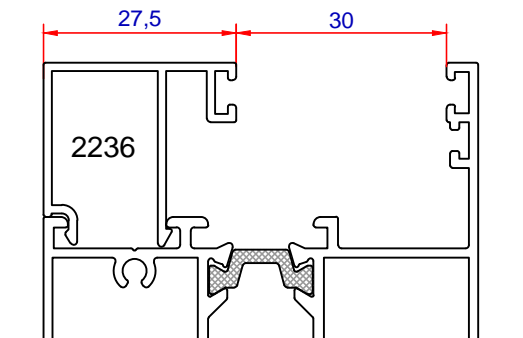
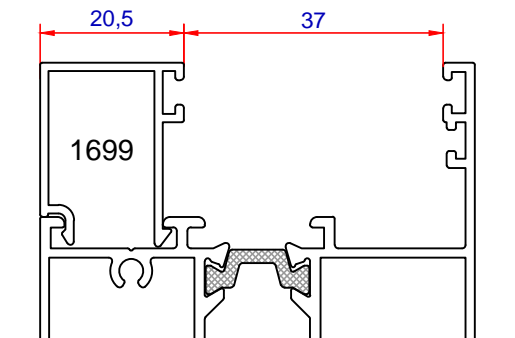
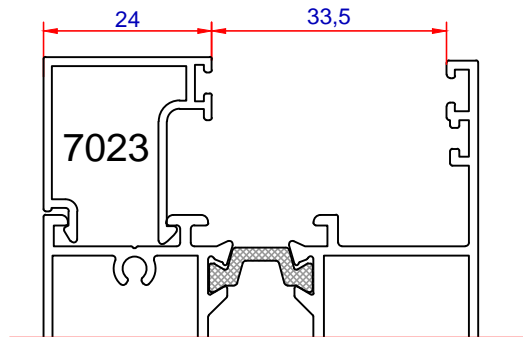
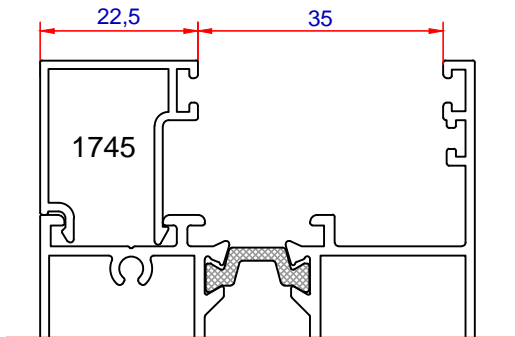
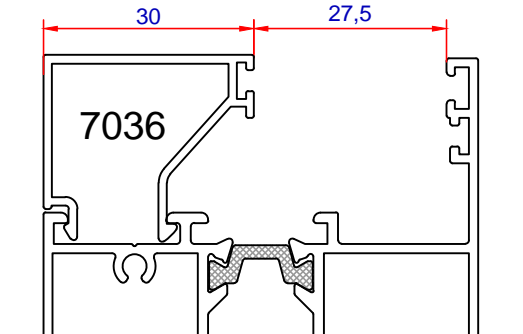
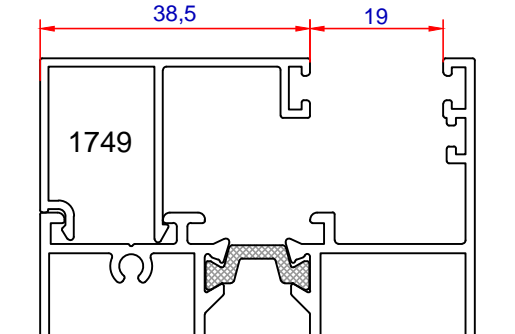

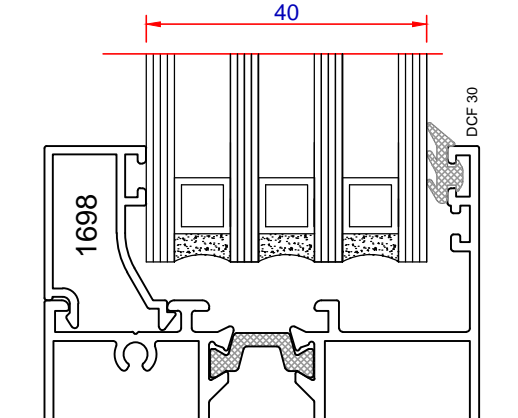
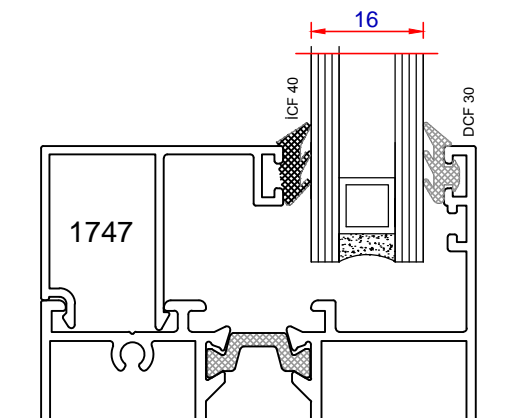
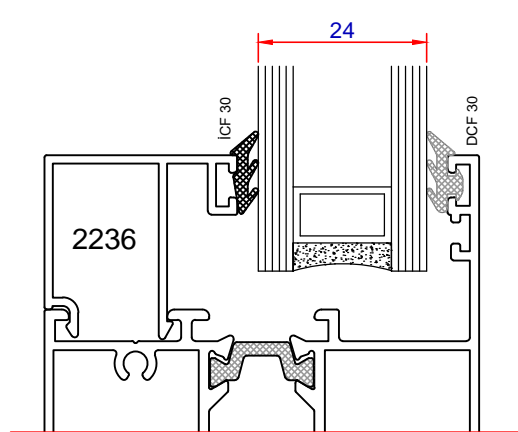
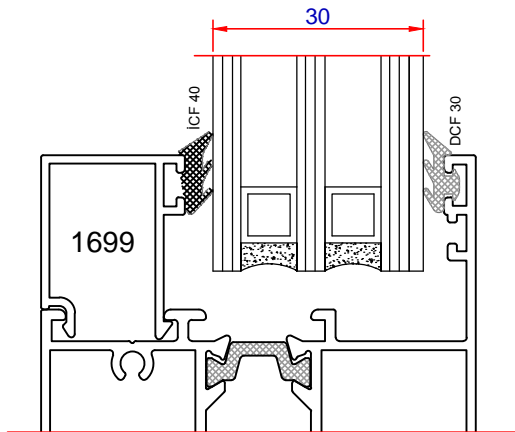
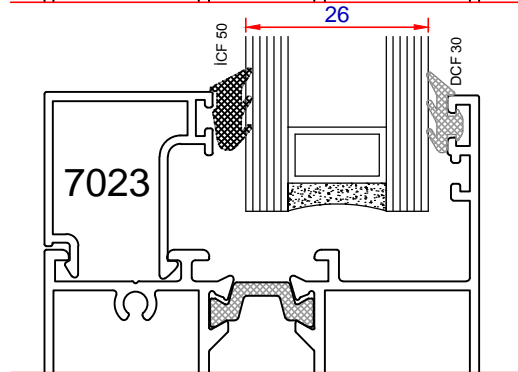
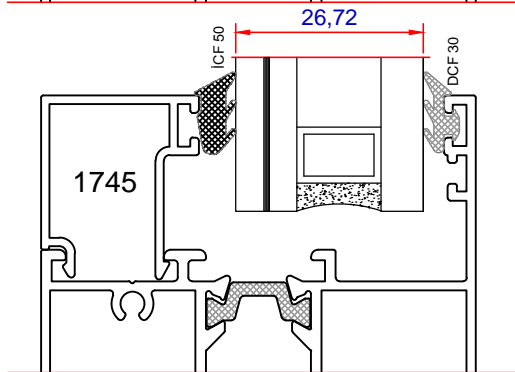
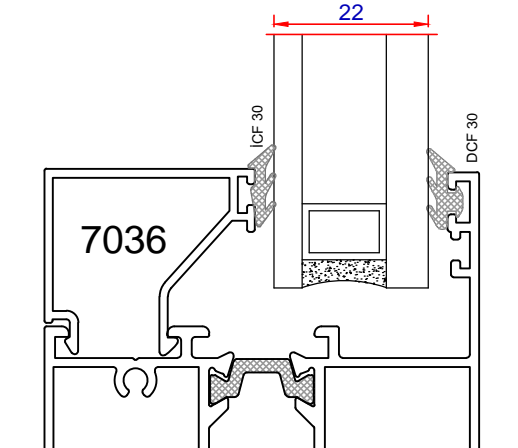
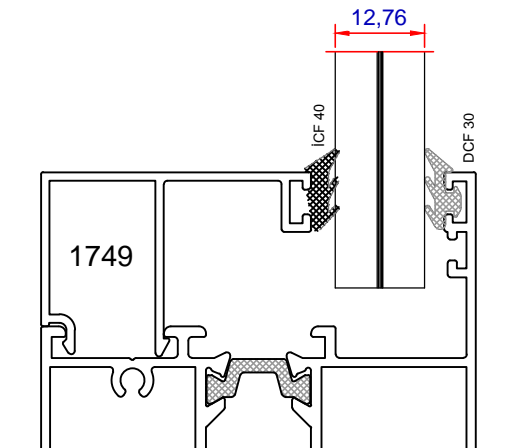





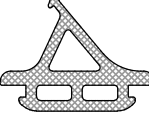

KOD NO.	ŞEKİL	ADI	MALZEME
03 010503		DCF 30 Dış Cam Fitili 3 mm	EPDM 1 Paket/15kg./320 Metre
03 011230		İCF 30 İç Cam Fitili 3 mm	EPDM 1 Paket/15kg./415 Metre
03 011231		İCF 40 İç Cam Fitili 4 mm	EPDM 1 Paket/15kg./360 Metre
03 010732		İCF 50 İç Cam Fitili 5 mm	EPDM 1 Paket/15kg./280 Metre
03 010440		KBF 40 Kulak Bini Fitili	EPDM 1 Paket/12kg./265 Metre
		OBF 50 Orta Bini Fitili	EPDM 1 Paket/13kg./60 Metre